

Hassco Workbench Tanks

1. 2" Threaded Fitting
2. 1 1/4" Vent
3. Top Cover with 2" Lip
4. Protective Plate
5. 1 1/2" Threaded Fitting
6. ULC Label
7. 1" Drain
8. 5" Channel

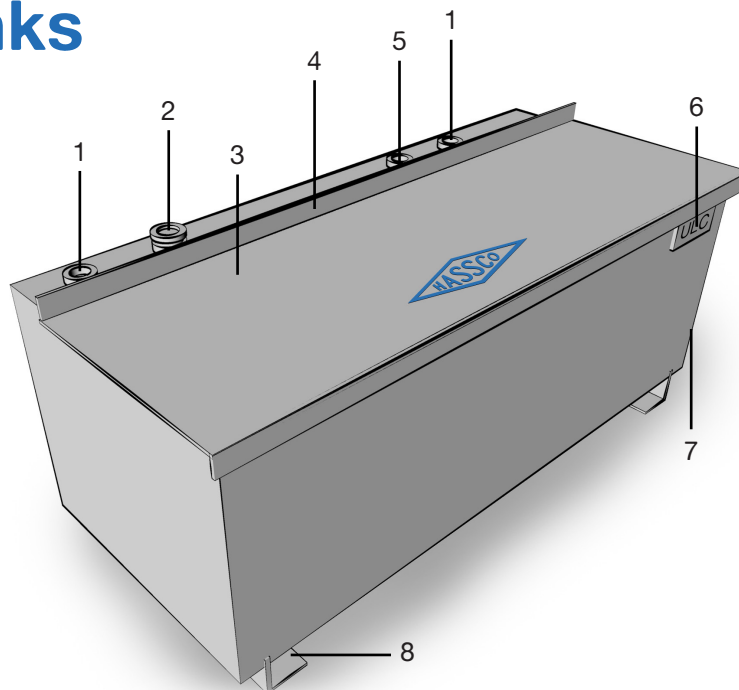

Material (gauge)	Capacity	Height	Length	Width	Weight
11 (tank) 7 (lid)	800L/180G	39" *	70" †	24"	350lbs.
11 (tank) 7 (lid)	1100LL/250G	37" *	70" †	36"	400lbs.

* includes channel † includes lip

General Information

HASSCO's Workbench Tanks are rectangular Single-Wall aboveground tanks that combine a working surface with storage of new lubricating oils. These tanks are best suited for garages, lube shops and general factories due to their dual-purpose design. All HASSCO tanks are phosphate washed prior to applying a high build metal treatment and two top coats of enviro-smart water based paint. Other coating options such as epoxy and powder are available upon request.

Options

- Tank gauges, high/low level alarms, heaters and pumping systems
- Powder Coating

Sizing

- 800L/175G & 1100L/250G

Conformity

- ULC

