

Hassco

Rectangular Mobile Refueling IBC

1. Handles
2. 2" Pump Outlet c/w Support Plate
3. Emergency Vent
4. UN/CGSB Label
5. 2" Fill c/w Lockable Vented Cap
6. Bolt Down Lugs
7. Skid Frame (on 680L and up)

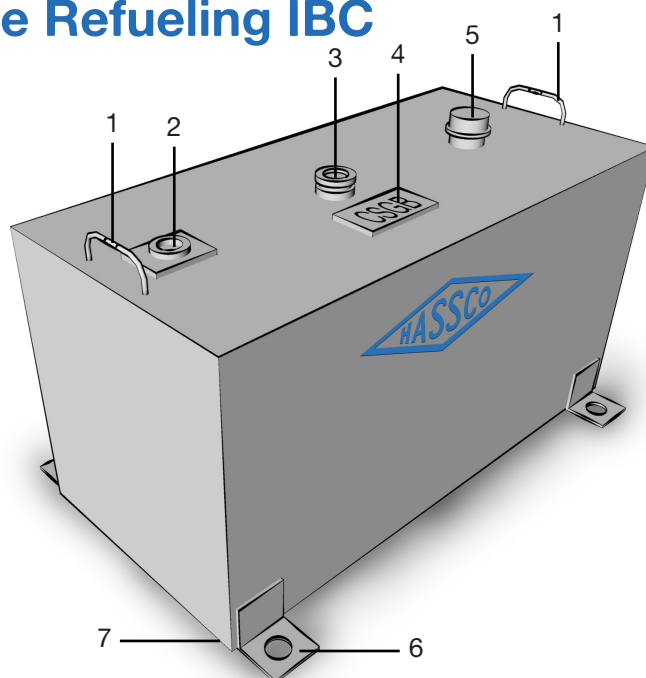

Material (gauge)	Capacity	Height	Length	Width	Weight
11	225L/50G	24"	24"	24"	115lbs.
11	450L/99G	24"	48"	24"	215lbs.
3/16"	680L/150G	24"	60"	30"	440lbs.
3/16"	900L/200G	31"	60"	31"	530lbs.
3/16"	1100L/250G	34"	60"	34"	620lbs.
3/16"	2200L/500G	40"	72"	50"	1100lbs.
1/4"	4500L/1000G	48"	96"	60"	2300lbs.

General Information

HASSCO's Transport Canada approved mobile IBCs are built tough to withstand the rigours of transporting fuel to any off-road/on-road location. All tanks come with a TransCAN approved vented fill cap, emergency vent, internal baffles and reinforced pump mounts. These tanks are best suited for applications requiring the transfer of flammable fuels. All HASSCO tanks are phosphate washed prior to applying a high build metal treatment and two top coats of enviro-smart water based paint. Other coating options such as epoxy and powder are available upon request.

Options

- Double wall version
- Transfer pumps and meters
- Powder Coating

Sizing

- Up to 5000L

Conformity

- Transport Canada\CGSB

